MultiModem *SDH*™

Models:

MT128ISA-UV

MT128PCI-SD

MT128PCI-SV

User Guide

MultiTech[®]
Systems 

User Guide

**Models MT128ISA-UV, MT128PCI-SD, MT128PCI-SV
PN: S000317**

Copyright ©2003 by Multi-Tech Systems, Inc.

All rights reserved. This publication may not be reproduced, in whole or in part, without prior written permission from Multi-Tech Systems, Inc.

Multi-Tech Systems, Inc. makes no representations or warranties with respect to the contents hereof and specifically disclaims any implied warranties of merchantability or fitness for any particular purpose. Furthermore, Multi-Tech Systems, Inc. reserves the right to revise this publication and to make changes from time to time in the content hereof without obligation of Multi-Tech Systems, Inc. to notify any person or organization of such revisions or changes.

Revision	Date	Description
-----------------	-------------	--------------------

A	11/15/2003	Updated manual to include Plug & Play driver installation. Previous edition 88300350.
---	------------	---

Trademarks

MultiModem, MultiModemISDN, Multi-Tech, and the Multi-Tech logo are trademarks of Multi-Tech Systems, Inc. All other trademarks are owned by their respective companies.

Patents

This device is covered by one or more of the following patents: 5,559,793; 5,546,448; 5,546,395; 5,535,204; 5,500,859; 5,471,470; 5,463,616; 5,453,986; 5,452,289; 5,450,425; 5,355,365; 5,309,562; 5,301,274. Other patents pending.

Technical Support

France	support@multitech.fr	+33 1-64 61 09 81
India	support@multitechindia.com	+91 124 6340778
U.K.	support@multitech.co.uk	+44 118 959 7774
U.S., Canada	support@multitech.com	(800) 972-2439
Rest of World	support@multitech.com	+763 717-5863

World Headquarters

Multi-Tech Systems, Inc.
2205 Woodale Drive
Mounds View, Minnesota 55112 U.S.A.
(763) 785-3500 or (800) 328-9717
U.S. FAX (763) 785-9874
Technical Support (800) 972-2439
www.multitech.com

Contents

Chapter 1 - Introduction	5
Product Overview	5
Product Description	5
Features	6
What Is in Your MultiModemISDN Package?	6
Manual Organization	7
Technical Specifications	8
Chapter 2 - Installation	9
Introduction	9
ISDN BRI Line	9
SPID (Service Profile ID)	9
NT1 Connection	9
S/T Interface	10
U Interface	10
Internet Access	11
Safety Warnings	11
Environment Setup	11
Hardware Installation	12
Software Installation	14
Before You Begin	14
Determining Modem Type	14
Configuring for Your ISDN Switch	16
ISDN Switch Type	16
Codec	16
Standby Time	16
SPID	16
MSN (POTS)	16
SAD	16
Protocol	16
Install the Modem Driver on Win 98/Me/2000/XP	17
Windows NT Installation and Configuration	17
Windows NT Single Channel Access (NDISWAN)	20
Windows NT Multilinked Channel Access (NDISWAN)	21
Windows NT and the CAPI Interface	22
Windows NT Single Channel Access (CAPI)	24
Windows NT Multilinked Channel Access (CAPI)	24
Windows NT Removal of the ISDN Drivers	24
Chapter 3 - AT Commands	25
Introduction	25
Commands and Descriptions	25
Chapter 4 - Troubleshooting	28
Introduction	28
Frequently Asked Questions	28
LineTest	30
ISDN LOG	31
ISDN Log Error Messages	32
Chapter 5 - Warranty and Service	33
Multi-Tech Systems, Inc. Warranty & Repairs Policies	33
Repair Procedures for U.S. and Canadian Customers	33
Repair Procedures for International Customers (Outside U.S.A. and Canada)	34
Repair Procedures for International Distributors	34
Online Warranty Registration	34

Service	35
U.S. and Canadian Customers	35
International Customers (outside U.S.A. and Canada)	35
International Distributors	35
Replacement Parts	36
Technical Support	36
Internet Sites	36
Appendix A - Regulatory Agency Information	37
FCC Part 68 Telecom Digital	37
Class B Statement	38
FCC Part 15	38
Industry Canada	38
Canadian Limitations Notice	38
EMC, Safety and Terminal Directive Compliance	39
Appendix B - APIs	40
VCOMM	40
CAPI	40
NDIS	40
Index	41

Chapter 1 - Introduction

Product Overview

Welcome to the world of ISDN communications. You have acquired one of the finest ISDN terminal adapters (TAs) available today, the MultiModemISDN from Multi-Tech Systems.

The proliferation of PCs and LANs with bandwidth-intensive applications has generated a powerful demand for high-speed connections. The worldwide standardization of ISDN, combined in many countries with its growing availability and falling cost, make it a natural choice for enhancing data throughput. Terminal adapters provide high-performance solutions for Internet access, file transfer, remote access service (RAS), and running existing modem applications through the ISDN network.

Product Description

The MT128ISA and MT128PCI are internal PC cards for IBM personal computers; and fit into a full-or half-sized expansion slot. There are two ISDN interface options, *ST* and *U*. If you purchased the *ST* interface adapter (MT128PCI-SD/SV), you need an ISDN NT1 device connection to the ISDN switch. If you purchased the *U* interface adapter (MT128ISA-UV), it can directly connect to the ISDN switch (figure 1-1).

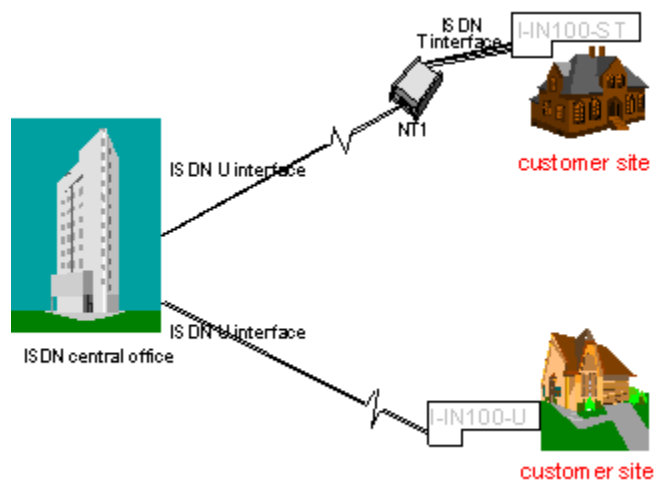

Figure 1-1. “ST” and “U” Interface Options

Your internal ISDN PC card is compatible with prevalent ISDN switch protocols. It communicates using ISDN BRI (2B+D) service, which provides up to 128K bps data communications.

This manual documents the following models:

- MT128PCI-SD for ST interface no POTS port
- MT128PCI-SV for ST interface with one POTS port
- MT128ISA-UV for U interface with one POTS port

All of the current analog devices, including telephone set, G3 fax, answering machine, modem, and PBX trunk line, can be connected to the POTS port via an RJ-11 jack in “V” models.

This User Guide will help you install, configure, and operate your terminal adapter.

Features

Your internal ISDN PC card features include:

- D Channel protocols including AT&T 5ESS, Nortel DMS-100, US NI-1 & NI2, ETSI and Japan INS-64.
- Full B Channel protocol set including V.110, V.120, HDLC, X.75 (Transparent T.70NL, EuroFT), MLP, async to sync PPP conversion and MLP+BOD and voice (V models).
- Bandwidth on demand (BOD) plus MLP Internet connection, RAS and related data communications capabilities.
- ISDN BRI (2B+D) and analog ports.
- Modem applications support with ISDN throughput and digital transmission quality, e.g., PC Anywhere.
- Video conferencing support without extra video CODEC hardware, e.g. Vdonet's Vdophone.
- Software implementation of G3 fax and modem capability with no extra hardware required.
- Supports Application Interfaces including WinISDN, CAPI 2.0, Windows Comm (AT command/S-Register/Result Codes) and NDISWAN Miniport.
- Automatic detection of incoming calls as voice or data (V models).
- Supports Windows 98, Windows NT and Windows 2000 Multilink PPP connection.
- Supports Microsoft ISDN Accelerator Pack or Microsoft Dial-up Networking.
- PnP compatibility.
- Ability to use the same communications software as analog modems.
- AT command $ATS30=n$, which automatically disconnects the active connection if there is no data traffic for $n \times 10$ seconds.
- Provides On-line test and Diagnostics tools.

What Is in Your MultiModemISDN Package?

Before installing your terminal adapter, check the package contents to ensure it includes:

- One internal ISDN PC adapter
- MT128-series System CD containing modem driver and User guide
- RJ-45 cable (6 ft.) for ISDN connection
- RJ-11 cable for POTS connection (V models only)
- Quick Start Guide
- RJ11-BTS adapter (UK only)

Note: If any of these items are missing, please contact Multi-Tech Systems or your dealer/distributor.

Manual Organization

This manual is divided into five chapters and three appendices:

Chapter 1 – Introduction and Description

Chapter 1 summarizes the product's features, lists its technical specifications, and provides an overview of the manual's organization.

Chapter 2 – Installation

Chapter 2 describes how to make all the physical and software driver connections necessary for your terminal adapter to operate in an ISDN environment.

Chapter 3 – AT Commands

Multi-Tech's ISDN adapters supports Microsoft Windows Comm. API interface. This interface is similar to a modem interface and enables existing applications based on AT commands to access ISDN. Chapter 3 describes AT commands used to control your MultiModem ISDN terminal adapter.

Chapter 4 – Troubleshooting

This chapter provides general and specific problem solving steps for use with the MT128 internal adapter. The chapter also includes information about this product's "LOG" utilities as well as the Windows 2000 "LINETEST" utility used for testing the ISDN line status.

Chapter 5 – Warranty and Service

Chapter 5 provides the terms of your 2 year warranty and describes how to get service.

Appendices

Appendix A - FCC Regulations

Appendix B - Application Program Interfaces (APIs)

Appendix C - Applications

Technical Specifications

Model Number(s):	MT128ISA-UV, MT128PCI-SD and MT128PCI-SV
Network Interface:	RJ-45 "S/T" Interface or RJ-45 "U" Interface RJ-11 POTS Interface (V models)
Switch Compatibility:	AT&T 5ESS, Nortel DMS-100, US NI-1 & NI2, ETSI, INS-64
B-Channel Protocols:	Voice, Data (56K, 64K, 112K or 128K HDLC), V.120, X.75, Async. PPP to Sync. PPP conversion
Voice Coding:	PCM: A-Law (Europe); u-Law (US)
Application Interfaces:	WinISDN, CAPI 2.0, Windows Comm. API with AT command sets (COM port emulation), NDISWAN Miniport for Windows 98, Windows NT and Windows 2000.
Supported Applications:	Applications with WinISDN interface such as NetManage's Internet Chameleon. Applications with CAPI interface such as RVS-COM. Applications with Windows Comm. API such as Microsoft HyperTerminal, PC Anywhere, Co-Session. Applications with NDISWAN interface such as Microsoft Dial-Up Networking and RAS.
Hardware:	16-bit adapter available in ISA bus, 32-bit adapter available in PCI bus, PnP for Windows 98, Windows NT and Windows 2000 systems.
Warranty:	2 years

Chapter 2 - Installation

Introduction

This chapter describes how to make all the physical and software driver connections necessary for your terminal adapter to operate in an ISDN environment. Please check the package contents list in Chapter 1 before beginning your installation.

ISDN BRI Line

Before running the ISDN adapter, you need to get an ISDN BRI (Basic Rate Interface) line from your local telephone company. Your ISDN service provider will provide information to you about the ISDN central switch type, pertinent subscriber information and SPID (Service Profile ID) number(s).

SPID (Service Profile ID)

The Service Profile ID (SPID) is applicable in the U.S. only. SPIDs are a series of numbers that inform the central office switch which services and features to provide to an ISDN device. The generic SPID format comprises 14 digits. The first 10 digits are the main telephone number on the terminal. The last 4 digits are dependent on the number of terminals on the interface and the services they support.

NT1 Connection

An ISDN Basic Rate (BRI) U-Loop consists of 2 conductors from the CO (telephone company central office) to the customer premises. The equipment on both sides of the U-loop has been designed to deal with the long length of the U-loop and the noisy environment it operates in. At the customer premises the U-loop is terminated by an NT1 (network termination 1) device. An NT1 is a device which provides an interface between the two-wire twisted-pairs used by telephone companies in their ISDN BRI network and an end-user's four wire terminal equipment. The NT1 drives an S/T-bus which is usually made up of 4 wires, but in some cases may be 6 or 8 wires.

The name of the S/T bus comes from the letters used in the ISDN specifications to refer to two reference points, S and T. Point T refers to the connection between the NT1 device and customer supplied equipment. Terminals can connect directly to NT1 at point T, or there may be a PBX (private branch exchange, i.e. a customer-owned telephone exchange). When a PBX is present, point S refers to the connection between the PBX and the terminal. Note that in ISDN terminology, "terminal" can mean any sort of end-user ISDN devices, such as data terminals, telephones, FAX machines, etc. The diagram which follows reflects interface points in a typical ISDN network.

If your ISDN product operates with a S/T outlet interface, you need an NT1 device to connect to the ISDN switch. MT128PCI-SD/SV adapters need an NT1 device to connect to the ISDN switch, but the MT128ISA-UV adapter does not require NT1 device. In the UK, and in many European countries, an NT1 device is supplied by your telephone company.

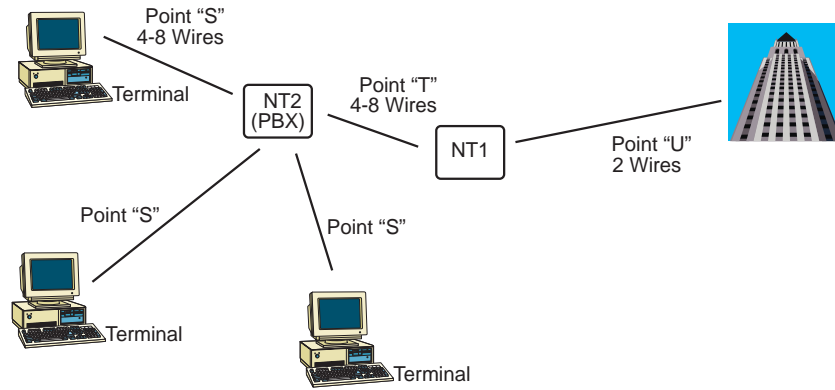

Figure 2-1 ISDN Interface Points

S/T Interface

The S/T interface uses an 8-conductor modular cable terminated with an 8-pin RJ-45 plug. An 8-pin RJ-45 jack located on the terminal is used to connect the terminal to the DSL (Digital Subscriber Loops) using this modular cable.

Table 2-1 shows the Pin Number, Terminal Pin Signal Name and SILC Pin Signal name for the S/T interface.

Pin Number	Terminal Pin Signal Name	SILC Pin Signal Name
1	Power Source 3	Not applicable
2	Power Source 3	Not applicable
3	Tx+	Rx+
4	Rx+	Tx+
5	Rx-	Tx-
6	Tx-	Rx-
7	Power Sink 2 (-)	Not applicable
8	Power Sink 2(+)	Not applicable

Table 2-1. S/T Interface Connector Specification

U Interface

The U interface uses a 2-conductor twisted pair cable terminated with an RJ-45 jack. An RJ-45 jack located on the terminal is used to connect the terminal to the Digital Subscriber Loops using this twisted pair cable.

In Table 2-2 the Pin Number, Terminal Pin Signal Name and UILC Pin Signal Names for the U interface are listed.

Pin Number	Terminal Pin Signal Name	UILC Pin Signal Name
1	Not Used	Not applicable
2	Not Used	Not applicable
3	Not Used	Not applicable
4	Tip or Ring	Tip or Ring
5	Tip or Ring	Tip or Ring
6	Not Used	Not applicable
7	Not Used	Not applicable
8	Not Used	Not applicable

Table 2-2. U Interface Connector Specification

Internet Access

If you want to use an ISDN adapter to connect to the Internet, you must get an Internet access account from an ISP (Internet Service Provider) in your country. You must also confirm with your ISP that they support either single channel ISDN (64K) or multilinked channel (128K) access.

Safety Warnings

1. Never install telephone wiring during a lightning storm.
2. Never install telephone jacks in wet locations unless the jack is specifically designed for wet locations.
3. This product is to be used with UL and cUL listed computers.
4. Never touch uninsulated telephone wires or terminals unless the telephone line has been disconnected at the network interface.
5. Use caution when installing or modifying telephone lines.
6. Avoid using a telephone (other than a cordless type) during an electrical storm. There may be a remote risk of electrical shock from lightning.
7. Do not use the telephone to report a gas leak in the vicinity of the leak.
8. To reduce the risk of fire, use only No. 26 AWG or larger Telecommunication line cord.
9. Ports that connect to other apparatus are defined as SELV. To ensure conformity with EN 41003, ensure that these ports connect only to the same type of port on the other apparatus.

Environment Setup

All ISDN adapter models are Plug and Play (PnP) compatible. Even if the BIOS or computer main board does not provide PnP feature support, the device driver still can automatically configure the ISDN card with the proper I/O addresses and IRQ number.

Hardware Installation

Note: Disregard step 1 for models MT128ISA-UV only, and proceed to step 2.

1. The ISDN S/T interface can support up to 8 ISDN terminals and NT1 device connecting to the ISDN network. Only one ISDN S/T device should have the terminator enabled. Normally, the ISDN terminal farthest from NT1 should have the terminator enabled. Models MT128PCI-SD/SV and MT128ISA-UV provide two jumpers (JP1 and JP2) for the terminator setup. The default setting for the adapter(s) is terminator enabled. If there are other ISDN devices connected to the NT1 with ISDN adapter(s), and you do not require your adapter as a terminator, remove the JP1 and JP2 shorting plugs (open circuit).

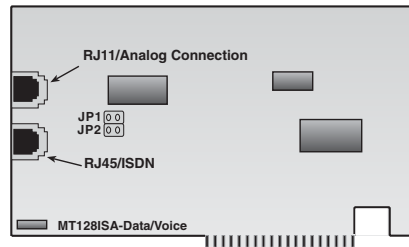

Figure 2-2. Internal ISDN ISA Adapter Illustration

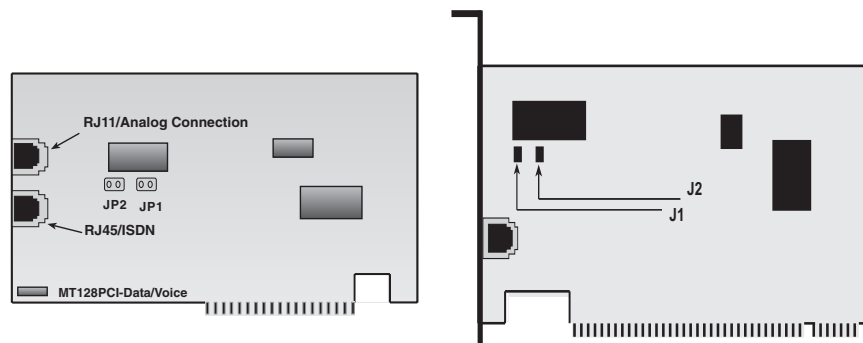

Figure 2-3. Internal ISDN PCI Adapter Illustrations

- 2a. Turn off your computer power and remove the PC cover.
- 2b. If you are using an ISA card, select an empty ISA slot for your adapter. If you are using a PCI adapter, select an empty PCI slot for your card. Remove the expansion slot cover and save the retaining screw.
- 2c. Before handling your adapter, discharge static in your body by touching a piece of grounded metal such as the computer chassis.
- 2d. Carefully remove the ISDN adapter from the antistatic bag, handling it only by the mounting bracket and edges. Do not touch the gold-plated connectors along the bottom edge.
- 2e. Place the adapter directly over the appropriate open slot. (If you are using an ISA adapter insert the card into the open ISA slot selected in Step 2b. If you are using a PCI card, insert the adapter into an open PCI slot.) Gently push the connector into place until the adapter is firmly seated and the retaining bracket is flush with the computer chassis. Fasten the bracket to the computer chassis with the screw removed in Step 2b.
- 2f. Replace the PC cover.

3. If you are using a voice model adapter (models MT128ISA-UV or MT128PCI-SV only) you may connect your current analog device to the RJ-11 *Phone* port. You can connect analog telephones, G3 fax, modem, or an answering machine with the RJ-11 connector cable.

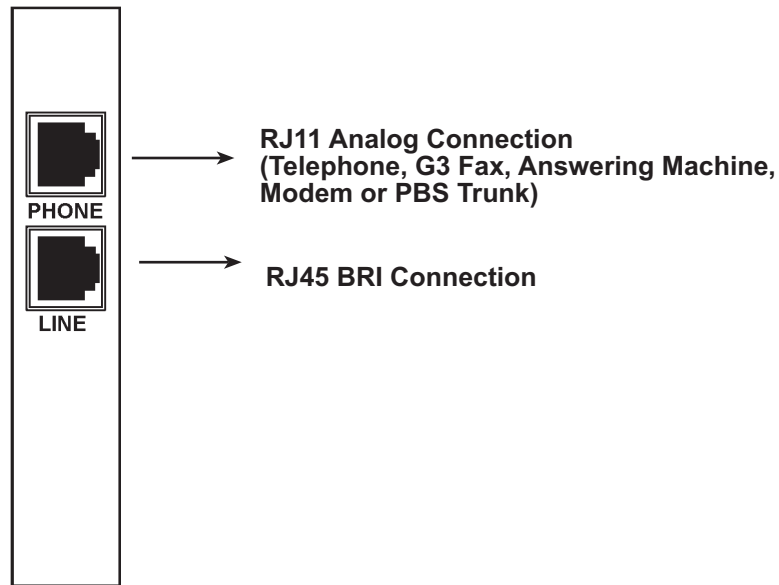

Figure2-4. Modular Analog and BRI Connections

- 4a. Make the ISDN connection by connecting the MT128PCI-SD/SV adapter and the NT1 with the RJ-45 cable connector, and insert the ISDN BRI line into the correct NT1 socket.
OR
- 4b. Insert the ISDN BRI line with the RJ-45 connector cable directly into the RJ-45 jack (*Line* port) on the MT128ISA-UV adapter.

Your ISDN PC environment is ready for software installation. The MT128PCI-SD/SV and adapters attach to the ISDN T interface from the NT1. The MT128ISA-UV adapter attaches to the ISDN U interface directly with ISDN switch.

Software Installation

Before You Begin

After installing the terminal adapter in your computer you'll need to install and configure the adapter drivers, then set up dial-up connections.

If your ISDN application uses the CAPI interface, install a CAPI compliant application such as RVS-COM Lite.

Before you can configure your software you need to determine how you plan to use your ISDN adapter. The MultiModem ISDN terminal adapter uses three basic APIs which are further described in Appendix B of this manual. In general:

- **NDISWAN** connections are used for connections to the Internet, a remote Local Area Network or for RAS installations. Upon installing NDISWAN the following adapters and protocols are installed on your system:
 - IINWAN95-ISDN Adapter
 - NDISWAN-IINWAN95-ISDN Adapter
- **VCOMM** or the Virtual Modem is used for ISDN applications that do not use networking protocols, (e.g., HyperTerminal or PCAnywhere).
 - ISDN (Internet MLPPP over X.75, 128K) Adapter
 - ISDN (Internet MLPPP+BOD over X.75, 128K) Adapter
 - ISDN (Internet MLPPP, 128K) Adapter
 - ISDN (Internet PPP over X.75, 64K) Adapter
 - ISDN (Internet PPP, 64K) Adapter
 - ISDN Universal-1 (64K) Adapter
 - ISDN Universal-2 (64K) Adapter
- **CAPI** allows for such functions as faxing. You'll need to install a CAPI compliant application such as RVS-COM Lite to use this API. Installing RVS-COM Lite will make the following modems available:
 - RVS ISDN
 - RVS ISDN Btx
 - RVS ISDN Fax
 - RVS ISDN HDLC transparent
 - RVS ISDN Internet PPP
 - RVS ISDN Minitel
 - RVS ISDN Modem Analog
 - RVS ISDN V.110
 - RVS ISDN V.120
 - RVS ISDN X.75 T.70NL
 - RVS ISDN X.75 transparent

Determining Modem Type

Refer to the following information for assistance in selecting the appropriate modem for your ISDN application.

- The Internet MLPPP protocol is for connecting to Internet Servers and other point-to-point (PPP) protocol servers using the Multi-Link Point-to-Point protocol. MLPPP is the only protocol which can link two ISDN B-channels to establish a 128 kilobits per second bandwidth data path.

Note: Before attempting to make a 128K MLPPP connection, verify that your ISP supports this feature.

- X.75 protocol is used mostly for BBS access and file transfer, but may be used for Internet access in some locales.
- The Universal-1 and -2 are multi-purpose modems. In Universal modem mode, the ISDN driver selects HDLC protocol as the default. You can change to the appropriate protocol through the *ATBn* commands (see Chapter 3). The AT command can be issued through

Start>Settings>Control Panel>Modems>ISDN modem>Properties>Connection, Advanced>Extra settings.

- The Internet PPP protocol is for connecting to Internet and other communications servers at 64 kilobits per second. Only one B-channel is used, leaving the other free (if supplied by your ISDN service provider) for a different data transfer operation or a voice or fax call.
- BOD means *Bandwidth on Demand*. BOD first establishes a 1B (64K) data channel and waits until data traffic is over the value specified in **ATS53** (see Chapter 3 for more information about AT commands). When data traffic goes over this default value (or the value set in the user-specified AT command), BOD establishes a second B channel and bundles it to a 128K communication link for better performance. BOD allows greater flexibility in handling voice and data calls simultaneously.

Bandwidth on demand is very useful where ISDN access is charged for by the minute, since the second B-channel is only used when the volume on the first B-channel has exceeded a threshold value for a certain period of time.

Before BOD activates all three of the following conditions must be met:

- Average data traffic is lower than the value (ATS53) in a specific period (ATS54)
- User wants to make an outgoing voice call (picks up the handset)
- There is an incoming voice call (ring signal on an analog telephone device)

Configuring for Your ISDN Switch

Regardless of the operating system or application you are using, the installation process will request information from you about the ISDN switch and your remote connection. Use the following information as a reference while configuring your software.

ISDN Switch Type

If you are not sure which switch type you are using, check with your ISDN provider.

Codec

Telephone companies use Codecs to convert signals transmitted over their networks. Telephone service providers that adhere to U.S. telecommunications standards use u-law. Many European and Asian telephone companies adhere to A-Law. Check with your ISDN provider if you are unsure which value to select.

Standby Time

Standby time is a timer which buffers any keypad's input from an analog device before sending a message out. In general, this value will not need to be changed from the default value.

SPID

Certain U.S. ISDN switch types require SPID (Service Profile ID) information be configured in your software. If required, your telephone company will provide the necessary SPID values. **SPID1** refers to the first ISDN line. **SPID2** refers to the second ISDN line.

MSN (POTS)

MSN (Multiple Subscriber Number) is a supplementary service generally used by European ISDN switches. MSN service provides the possibility of assigning multiple ISDN numbers to a single interface. The POTS field is used to enter the phone number associated with a voice line. In a two channel ISDN configuration, if the MSN (POTS) field is left blank, either number can ring. If a phone number is entered, the number dialed on the incoming call must match the MSN (POTS) value for the analog device connected to the POTS (voice) (a/b) port to be enabled.

SAD

SAD (Sub addressing) is used by certain European ISDN providers. If subaddresses are available in your area enter the phone number in the format, 7706043*1, where 7706043 is the called (remote) phone number and 1 is the subaddress. The phone number and subaddress are separated by *.

Protocol

In some configurations, you will need to select HDLC, X.75 Transparent, V.120 or Auto-Detection as your incoming protocol. The incoming protocol selection is based upon the protocol of your ISDN adapter. The outgoing protocol selection is based upon the protocol of the remote ISDN device to which you are connecting.

Install the Modem Driver on Win 98/Me/2000/XP

For Windows 98/Me/2000/XP operating systems, install the modem driver using the Windows Plug and Play feature. Follow the procedure below to install the modem driver.

1. Verify the modem is properly connected, then turn on the computer. Windows will detect the new modem and open the **Install New Hardware** wizard.
2. Insert the MT128-series system CD.
3. Point to the Drivers folder on the CD (Drivers/Win98_Me or Drivers/Win2000-XP). Click OK at the Install New Hardware prompt.
3. Windows will install and configure the modem.
4. Click **Finish** at the prompt to exit.

Windows NT Installation and Configuration

Note: To install, configure and remove devices under NT, your logon permissions must include the ability to load and remove device drivers.

Your internal ISDN PC adapter under Windows NT can be used with NDISWAN or the standard CAPI interface. Once you've inserted the ISDN card into the computer and switched on the power for your computer, it should boot into Windows NT. Follow the instructions below to install the ISDN driver:

1. Click **Start>Settings>Control Panel>Network>Adapter> Add**
2. Click **Have Disk** and specify the correct drive for the NT ISDN Installation disk/CD.
3. On the *Select OEM Option* Screen, select the **ISDN MT128ISA Adapter**. Click **OK**.
4. The ISDN Driver Bus Location dialog box appears. Select the proper bus type for your installed adapter. If you are using an ISA adapter, select ISA. If you are using a PCI adapter, select PCI. Set the Bus Number to 0. Click **OK**.
5. Windows NT copies the ISDN driver into your system and displays the ISDN PC Adapter Configuration screen as shown in figure 2-5.

Note: If the ISDN PC Adapter Configuration screen does not appear automatically or if you need to edit your ISDN Switch configuration, return to this screen by selecting **Start>Settings>Control Panel>Network**. Right click and select **Properties**.

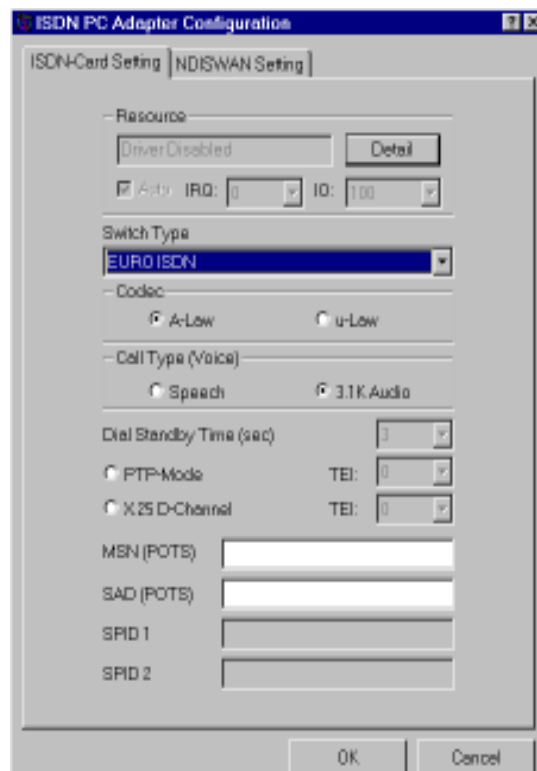

Figure 2-5. ISDN PC Adapter Configuration

6. Use the list box to select the Switch Type. If you are not sure which Switch Type to select, contact your ISDN provider. If your telephone service provider uses MSN (Multiple Subscriber Numbers) or SAD (Sub-Addressing), enter the information given to you by your ISDN provider in the appropriate fields. If your ISDN service requires SPIDs (Service Provider IDs), enter these values in the SPID1 and SPID2 fields. Refer to Chapter 2 "Before You Begin" for more information.

Note: If you plan to use PTP Mode (Point to Point Mode) or X.25 select those options here.

7. Click on the NDISWAN Setting tab and enter any necessary phone number information.

Note: After installation and any time you make changes to values within the ISDN configuration dialog box, you will need to restart Windows NT for the settings to take effect.

8. When complete, Click **OK** to continue. The RAS Setup Message appears as shown in figure 2-6. Click **OK** to continue the installation.



Figure 2-6. Remote Access Service Setup Message

9. Click **OK** to install and setup RAS.
10. The screen shown in figure 2-7 appears.

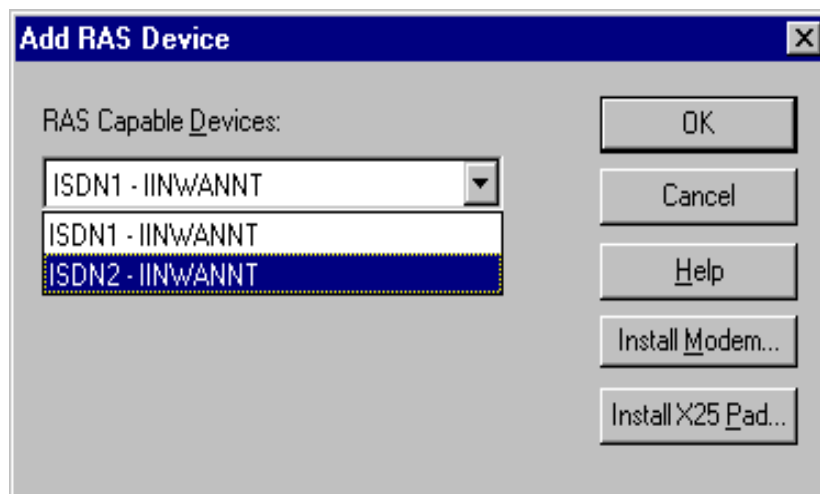

Figure 2-7. Adding a RAS device

11. If you do not see *ISDN1-IINWANNT* listed in the port fields, click **Add**.
12. From the list box, select *ISDN1-IINWANNT* and click **OK**. The first NDISWAN device is added to the Remote Access Setup Port list.

13. Add your second NDISWAN ISDN device by clicking **Add** and selecting *ISDN-2-IINWANNT* from the list box. Click **OK** to add this device to the RAS Setup as shown in figure 2-8.

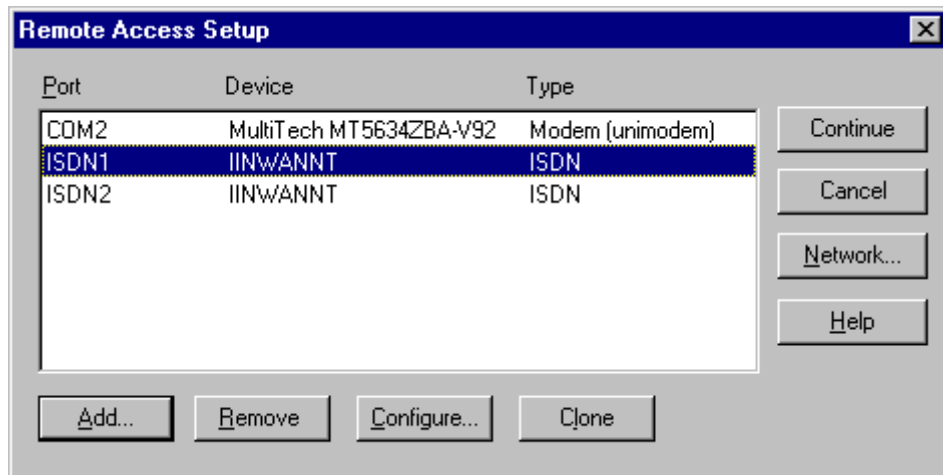

Figure 2-8. Remote Access Services (RAS) Setup

14. Select the ISDN1 and click **Configure** to setup Port Usage for this ISDN1 port. Depending upon your use of this channel, select *Dial out only*, *Receive calls only*, or *Dial out and Receive calls*. Click **OK**.

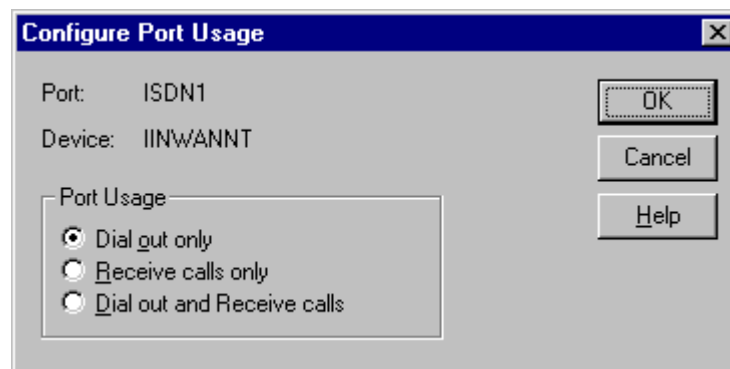

Figure 2-9. Configure Port Usage Installation

15. If you choose *Dial out only*, click **OK**, and then click the **Network** tab. Select the protocol you will use. If you are going to access the Internet, choose **TCP/IP**.

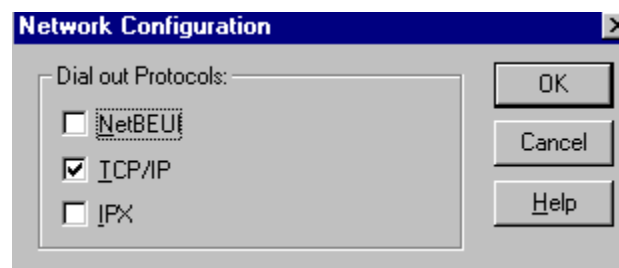

Figure 2-10. Configure Dial Out Protocol

16. If you Select *Receive calls*, or *Dial out and Receive calls*, click **OK**, then click the **Network**

tab. The screen displayed in figure 2-11 appears. Contact your ISP or network administrator if you require assistance in configuring your TCP/IP settings. Also check that you have enabled, *allow any authentication including clear text*, in the *Security* settings. Click **OK**.



Figure 2-11. Define Network Configuration

17. Select *ISDN2* and click **Configure** to set up the appropriate values for the second line.
18. You have completed your ISDN driver installation and have added two NDISWAN adapters. Click **Continue>Close**. NT will bind the appropriate drivers to your adapter and you will be prompted to restart your computer.

Windows NT Single Channel Access (NDISWAN)

Once your adapter is installed, you are ready to set up an ISDN Dial-Up Networking connection for single channel access.

1. Select **Start>Programs>Accessories>Dial-Up Networking**. If there are no previous entries in your phonebook, a dialog box appears stating *The Phonebook is empty. Press OK to add an Entry*. The New Phone book entry wizard appears. Enter a name for your new Phone Book entry. In the *Dial Using* field, select the *IINWANNT NDISWAN* adapter you will use for this connection.
2. Next, enter the primary phone number for your ISP or remote server. If you need to specify a Country, Region or Area code, click on the Telephony dialing properties box and fill in your dialing information. If your ISP or remote server *has more than one phone number that can be dialed*, click on **Alternate Phone Numbers** and add the phone numbers to the screen.
3. On the **Server** tab, select the correct remote Server Type. Click on **TCP/IP** to set up addresses for your remote server. Click **OK** to continue.
4. When complete, click **OK>Close**.
5. To use this new connection, open the Dial-Up Networking folder and select the NDISWAN single channel access entry from the phonebook entry drop down list box. Click **Dial**.
6. Enter the user name and password for your ISP or remote server account and click **OK**. Your adapter will connect in seconds.

Windows NT Multilinked Channel Access (NDISWAN)

Before beginning installation of a 128K MLP connection, verify your ISDN provider offers 128K MLP service and that it is enabled on the remote server.

In the following example the single channel access connection created in the previous section will be modified to support a 128K MLP connection.

1. Open the Network Dial-Up Connection folder and select the NDISWAN Single Channel Access connection created in the previous section.
2. Click the **More** button and select **Edit entry and modem properties**.
3. Under the **Basic** tab, use the *Dial Using* field list box to select **Multiple Lines**.
4. Click **Configure** and place a check mark in the boxes corresponding to *IINWANNT(ISDN1)* and *IINWANNT(ISDN2)*.

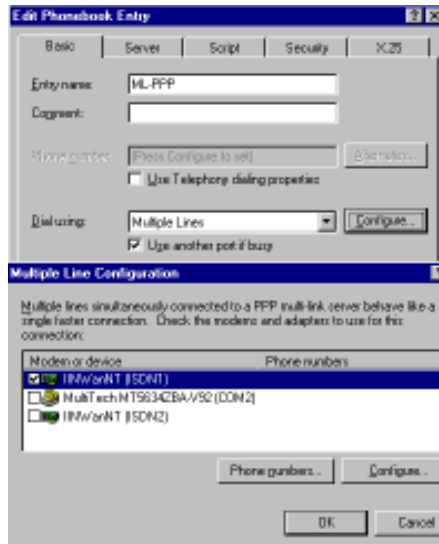

Figure 2-12. Multiple Line Configuration

5. Highlight *IINWANNT(ISDN1)*. Click **Phone numbers** and enter the phone number for the first ISDN line if it is not yet installed. Click **Add**, then **OK**.
6. Next, highlight *IINWANNT(ISDN2)*. Click **Phone numbers** and enter the phone number for the second ISDN line. Click **Add**, then **OK**. Click **OK** again to close the screen.
7. You are ready to make a connection with your ISP or remote server using multilinked channels. To use this new MLP connection, open the Dial-Up Networking folder and select the NDISWAN multiple linked channel entry from the phonebook entry list box. Click **Dial**.
8. Enter the user name and password for your ISP or remote server account and click **OK**. Your adapter will connect in seconds.
9. After dialing, the Dial-Up Monitor icon appears in the lower right hand corner of your screen. Double click on this icon to view your connection status including connection speed, server type, etc.

Note: If you have problems with the connection (such as the line being dropped or inability to access the Internet or your remote network), review the network settings with your ISP or network administrator. You also may want to test accessing the connection without using Multilinking.

Windows NT and the CAPI Interface

Before using the standard CAPI interface, install a CAPI compliant application such as RVS-COM Lite.

Under NT, The CAPI modems available through RVS-COM must be added as modems and also made available through RAS (Remote Access Services). To add a new modem:

1. Select **Start>Settings>Control Panel>Modems>>Add**
2. Select *Don't detect my modem, I will select it from a list.*
3. On the Install New Modem screen, select *RVS Datentechnik* from the Manufacturers list on the left side of the window. The RVS modems will display in the models column on the right side of the window. Select the RVS-COM modem you would like to use for your ISDN connection (in this example *RVS Fax* has been selected). Click **Next** to continue.

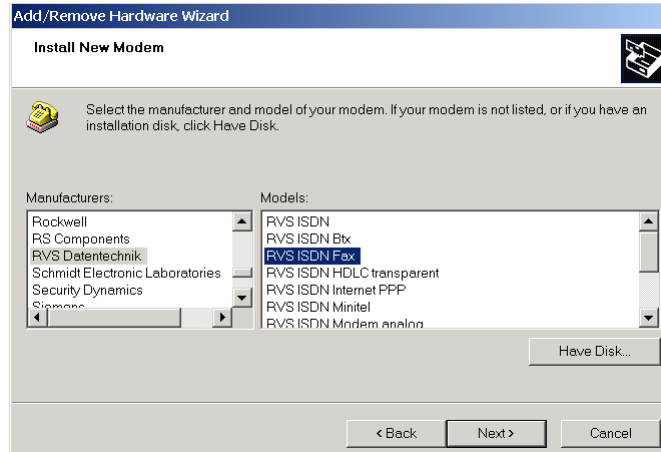

Figure 2-13. Selecting an RVS-COM modem

4. On the screen which follows, select the port you'd like to associate with this modem. Click **Next>Finish** to finish adding this first modem. You may press **OK** when complete. If you will be using linked channels, Add the second modem at this time by repeating the steps above. Associate the second modem with a unique COM port.
5. The screen shown in figure 2-14 appears asking if you would like to configure Dial-Up Networking. Respond by clicking **Yes**.

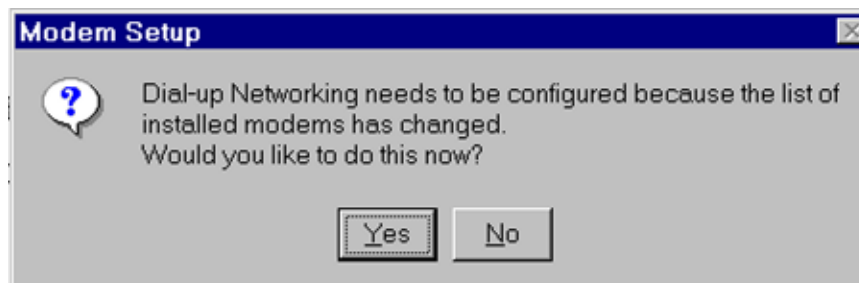

Figure 2-14. Dial-Up Networking dialog box

6. The Remote Access Setup Screen displays (figure 2-15).

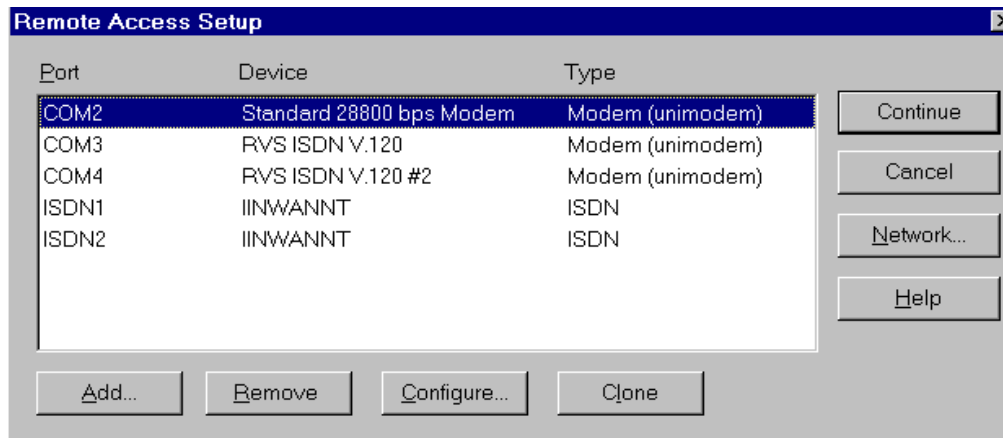

Figure 2-15. Selecting the CAPI (RVS-COM) device in RAS

7. Add the RVS-COM device to Remote Access Services by clicking **Add**. From the device list, highlight the desired modem and click **OK**.
8. With the newly added device highlighted, click **Configure**. You will be presented with the *Configure COM Port Usage* screen. Select an available ISDN COM port for this device and select either **Dial-Out only**, **Receive Calls Only** or **Dial-Out and Receive calls**. Click **OK** when complete.
If you will be setting up 128K MLP access, you may click **Add** on the Remote Access Setup screen and add the second RVS-ISDN device. When the second device has been added, highlight this new device and click **Configure** to define the COM port usage for this channel.
After adding the devices to RAS for this connection, click **Continue**. Restart the computer as prompted.

Note: If you add a modem at a later date, it must be added to Windows NT RAS before it can be used.

To add the modem to RAS:

1. From your NT desktop, right click on Network Properties and select **Properties**.
2. Click the **Services** tab.
3. When the RAS Services screen appears, select **Add**.
4. Select the modem you'd like to use with your application. Next, press **Continue**.
5. Associate the modem to a unique COM port and save the connection.
6. When the Network Properties screen closes you will be prompted to restart the computer.

Windows NT Single Channel Access (CAPI)

The RVS-COM installation makes several RVS-COM (CAPI compliant) modems available. Once they are added as modems and set up under RAS, you are ready to set up your Dial-Up connection.

1. Set up the Dial-Up Networking connection by selecting **Programs>Accessories>Dial-Up Networking**.
2. Click **New**. Provide a descriptive name for this connection and enter the phone number for your remote server or ISP.
3. Next, select the CAPI (RVS-COM) modem and COM port for this connection in the *Dial-Using* field.
4. When complete, click the **Server** tab and verify the Dial-Up server type. Click the **TCP/IP** settings tab if you need to specify IP addresses for your remote server or DNS. Contact your ISP or network administrator for information on configuring this screen.
5. Click **OK** to return to the Network Dial Up folder.
To use this connection, highlight the connection and click **Dial**. Your ISDN adapter will connect within seconds.

Windows NT Multilinked Channel Access (CAPI)

Before a second channel can be linked using CAPI, a second port must be defined within RVS-COM.

1. To make the second port available, open the RVS-COM Comm Center.
2. Click the **Services** tab. In the Virtual COM Ports section of the window, place a **check** mark in front of *both* ports. Associate each port with a unique COM port number (the two devices must use different COM ports.) Click **Apply**, then **OK**.
If the second CAPI device has not been installed add a second RVS-COM modem and make it available through RAS as described previously in this section.
You are now ready to create your Dial-Up Networking connection for multilinking. In this example, the Single Channel Access connection will be modified to allow for multilinking.
1. Click on **Programs>Accessories>Dial-Up Networking**.
2. Select the Single Channel CAPI connection and click **More**. Select **Edit entry and Modem Properties**.
3. In the *Dial Using* list box, select **Multiple Lines**.
4. Next, press **Configure**. Place a **check** mark in the box associated with the *two* RVS-ISDN lines you will be linking.
5. Highlight the *first* line and select **Phone Numbers**. If not previously entered, enter the phone number for this line. Click **Add** and **OK**.
6. Highlight the *second* line and select **Phone Numbers**. If not previously entered, enter the phone number for this line. Click **Add** and **OK**.
To use this 128K MLP Dial-Up connection, click **Programs>Accessories>Dial-Up Networking**. Double click on this newly created CAPI multilink connection. Both phone lines on your MultiModem ISDN adapter will connect in seconds.

Windows NT Removal of the ISDN Drivers

To remove the ISDN Driver in Windows NT, Click **Start>Settings>Control Panel>Network Icon>Adapters**. Select the *Multi-Tech ISDN Driver*. Click **Remove**.

You will be prompted to reboot your system when you exit the network properties dialog box. You must reboot for the changes to take effect.

Chapter 3 - AT Commands (Win 98 Only)

Introduction

AT commands are the means by which you and your communications software are able to communicate with and configure your ISDN adapter. These commands enable you to establish, read and modify parameters associated with your ISDN connections, line protocols and call handling. The following provides a list of the AT commands recognized by Multi-Tech's MultiModem ISDN terminal adapters.

Where indicated below, the AT prefix must be issued with the command. The AT command tells the modem "ATtention!, commands to follow". If you issue AT as a command by itself, the adapter should respond OK, indicating that your cables are connected correctly and your baud rate is set properly.

AT commands are entered in HyperTerminal mode or can be issued as an extra setting for your connection. Use **Start>Settings>Control Panel>Modems>ISDN Modem>Properties>Connection>Advanced>Extra settings**.

Commands and Descriptions

ATA	Answer an incoming call
ATBn	Select protocol of transmission in B channel
ATB0	64K HDLC (default with universal modems under Win95)
ATB20	V.120 Async.
ATB21	V.120 Sync.
ATB3	X.75 Transparent, the same as ATB30 (default with ISDN X.75 Transparent modem under Win95)
ATB30	X.75 Transparent
ATB31	X.75 T.70 NL
ATB32	X.75 ISO 8208
ATB4	Async PPP to Sync PPP converter (default setting with Win95 Async to Sync PPP modem)
ATB41	Async to Sync PPP conversion in ML PPP mode, compatible with Microsoft ISDN Accelerator pack
ATB42	Async to sync PPP conversion to MLPPP
ATB43	Async to sync PPP conversion in MLPPP+BOD (bandwidth on demand)
ATB6	Async to sync PPP conversion over X.75 transmission
ATB61	Async to sync PPP conversion over X.75, <i>but setting up secondary device in Dial-Up Networking required.</i>
ATB62	Async to sync PPP conversion in MLPPP over X.75
ATB63	Async to sync PPP conversion in MLPPP+BOD over X.75
ATDs	Dial a telephone number
ATDL	Dial the last number
ATD7693007	Dial telephone number 7693007
ATEn	Echo characters when in command mode
ATE0	Echo off
ATE1	Echo on (default)
ATHn	On-Off Hook
ATH	On-Hook, Disconnect (same as ATH0)
ATH1	Off-Hook
ATI	Display version number, selected protocol, packet size, connected speed, MSN, and outgoing call number.
ATO	On-Line command, switch to on-line from command mode
ATQn	Return the result code
ATQ0	Return the result code (default)
ATQ1	Does not return the result code
ATSr	Set or display the register value
ATS0=1	Set register 0 to 1, (S0=0 default, disable the auto-answer mode)
ATSr?	Display register content

ATS1?	Register 1 is read only, display the ring count
ATS2	Escape code character (S2=43, ASCII "+")
ATS3	Carriage return character (S3=13, representing a carriage return)
ATS4	Line feed character (S4=10, representing "CTRL J" or the linefeed character)
ATS5	Back space character (S5=8, representing "CTRL H")
ATS7	Wait for carrier after dial (S7=30 seconds default)
ATS12	Escape code guard time (S12=50 default)
ATS25	Delay to DTR (S25=5 default)
ATS30	Disconnects automatically if no data transmission in $n=10$ seconds ($n=0$ to 255; default is S50=0, so it does not disconnect connection)
ATS38	Windows size of HDLC 56K or 64K, 7 default
ATS39	Packet size of HDLC 56K or 64K from 1 to 2048, 2048 default
ATS40	Windows size of V.120, 7 default
ATS41	Packet size of V.120, 256 default
ATS44	Window size of X.75 (Transparent), 2 default
ATS45	Packet size of X.75 (Transparent) from 1—2048, 1024 default
ATS46	Window size of X.75 T.70 NL, 2 default
ATS47	Packet size of X.75 T.70 NL from 1 to 2048, 130 default
ATS50	Window size of X.75 ISO 8208, 2 default
ATS51	Packet size of X.75 ISO 8208 from 128 to 2048, 1024 default
ATS53	Average data flow from 1000 to 7000 bytes (default is 4, which is 4000 bytes). Activates second channel if average data flow is over 4000 bytes in 10 seconds.
ATS54	Time period from 5 to 20 minutes (default is 5). Disconnects second channel if average data flow is below n bytes (set by ATS53) in 5 minutes. Only available in MLPPP BOD mode, ATB43.
ATVn	Verbose command
ATV0	Return digit result code
ATV1	Returns word result code (default)
ATXn	Enable extended result code
ATZ	Reset
+++	Escape command
AT&Cn	Control DCD
AT&C0	Keep always the DCD line ON (the same as AT&C, default)
AT&C1	DCD line is active if connected
AT&E	Select the line speed in the B channel
AT&E0	64K bps (default)
AT&E1	56K bps
AT&F	Reset registers to factory setting
AT&R	Request to send
AT&S	Handle DSR
AT&S0	Keep DSR always ON (the same as AT&S)
AT&ZIn*m	Filter the incoming call and accept it when called party number is the same as n and called party subaddress is the same as m (option, * is the subaddress symbol)
AT&ZOn*m	Make a call with this caller party number (n * m). "n" is the local telephone number, "*" is the sub address symbol, if needed Command Description (option), and "m" is the sub address (option).
AT#C	Caller ID setting
AT#C?	Display the current Caller ID mode
AT#C0	Disable Caller ID (default)
AT#C1	Enable Caller ID

Chapter 4 - Troubleshooting

Introduction

This chapter provides a list of questions and answers for commonly asked questions about your MultiModemISDN adapter. In the last part of this chapter you will find information about the "LINETEST" and "LOG" utilities used for diagnosing ISDN line problems. If you are not able to resolve the issues after reading this section, contact our Technical Support department (see Chapter 5 of this User Guide for more information).

Frequently Asked Questions

- Q:** *How can I get the driver version number?*
- A:** In Win98, run HyperTerminal with a virtual modem connected to ISDN Com1 or 2, enter the ATI to display the version number. You may also run LOG32.EXE to view the version number (Version 2.21 or later). In Windows 2000, you may find the driver version by placing your cursor over the LINKSTS icon on the task bar.
- Q:** *How can I update the ISDN driver to a new version?*
- A:** Download the latest ISDN PC adapter driver form Windows 98, NT and 2000 from our web site at <http://www.multitech.com>. In Windows 98, run UPGRADE.EXE to update the driver automatically, then reboot your system. In Windows NT, remove the existing driver, reboot your system and install the new version. You will need to reconfigure the software for your ISDN switch type.
- Q:** *Why can't I use HyperTerminal to dial? (Win 98 only)*
- A:** Make sure HyperTerminal is configured with a virtual modem corresponding to the ISDN COM port. If you do not have two virtual modems with ISDNCom ports added use Start>Settings>Control Panel>Modems>Add. Select Have Disk and locate the proper file in the modem subdirectory of the installation diskette.
- Make sure the same protocol is used on both sides. Refer to the ATBn command (see Chapter 3) to set up the correct protocol used on the B channel. ATi will display the current settings.
- Q:** *Why can't I make a data connection through HyperTerminal? (Win 98 only)*
- A:** Ensure the client and remote sides of the connection are using the same protocol to make a data connection. You may use the ATBn command to set the protocol (refer to AT Commands in Chapter 3 of this manual). Enter ATi to display information such as Software version number, B channel protocol, connection speed, packet size, current MSN and current outgoing phone number for billing.
- Q:** *How can I monitor the ISDN line and make sure the ISDN card and line are working properly?*
- A:** When the system boots up and invokes the ISDN driver, the driver will initialize the ISDN card and selftest the IRQ, I/O, and chipsets. If you do not see any error messages, the ISDN card and driver are working properly. In Windows 2000, you may run LINETEST.EXE to perform a line test. It will ask you to enter an ISDN telephone and make a call. Enter a local number to do a loopback test from your site to the ISDN switch. This will ensure the D and B channels are working properly. Error messages 3301 and 3302 indicate a problem with the ISDN line.
- Q:** *How can I enable Caller ID in HyperTerminal?*
- A:** The driver does not display Caller ID as a default. If you want to enable Caller ID, enter the command, AT#C1 and AT#C0. To disable Caller ID, enter AT#C? to give the current status of Caller ID mode. This function is provided in Version 2.13 and later.

- Q:** *Why does the Internet connection not work when I upgrade to V2.13 or later?*
- A:** When you upgrade to V2.13, you'll need to remove the existing virtual modems and read them into the system. You can add the virtual modems using the following steps:
1. **Start>Settings>Control Panel>Modem>Add>**Select *Don't detect my modem, I will select it from a list.* **Next>**Select the modem and click **Have Disk**. Browse to the location of the installation diskette and select **MDMASU.INF**. Click **OK>** select the *ISDN Universal-1 Modem*, **Next>** associate this modem to ISDN COM port 1.
 2. Use the previous step to select the *ISDN Universal-2 Modem* > associate this second modem to ISDN COM port 2.
- Note:** *You may also use the Async to Sync PPP modem or the X.75 transparent modem. You'll also find these files in the modem sub-directory of the installation disk.*
- Q:** *Why can't I see the correct characters in the HyperTerminal screen when I get a connection with a remote site?*
- A:** Check to make sure the B channel protocol is the same on both sides of the connection. Check that the character is 8-bit ASCII or 7-bit ASCII. You can disable the first bit of 8-bit ASCII to 7-bit ASCII by opening the HyperTerminal settings and changing the terminal type to VT100. Click the ASCII Setup. In the ASCII receiving section, select "Force incoming data to 7-bits ASCII". Click OK.
- Q:** *Why can't I see the ISDN ports in RAS after installing the ISDN driver in WinNT?*
- A:** Follow these steps:
1. Remove the ISDN card via **Start>Settings>Control Panel>Network, ISDN card, Remove**.
 2. Reboot the computer.
 3. Install the ISDN driver.
 4. Redefine the modems to RAS. The two ISDN ports will appear.
- Q:** *How can I set the phone number for outgoing calls and MSN checking for incoming calls using the NDISWAN interface in WinNT?*
- A:** In WinNT, set MSN1, MSN2, calling party 1, and calling party 2 for the two NDISWAN ports by using **Start>Settings>Control Panel>Network>IINWANNT ISDN Adapter>Properties>NDISWAN setting**. Enter the subaddress information if applicable for your ISDN switch, otherwise, leave these fields blank.
- In most installations, the phone number for outgoing calls is used for billing. MSN is used to screen and accept preferred incoming calls.
- Q:** *Why does Windows NT detect the ISDN card and request to install its drivers when Windows NT boots up?*
- A:** Windows NT is not a PnP operating system. If Windows NT detects a PnP card during start up, the operating system has previously installed ISAPNP (this is commonly installed with sound cards such as SB16 or AWE32). When Windows NT requests ISDN driver installation, check *Do not install a driver* and NT will not prompt you again at boot up. Follow the NT installation instructions in this User Guide to install the NT drivers.
- Q:** *Why doesn't Windows NT RAS detect the ISDN Driver?*
- A:** If RAS is not installed on your computer and you install the ISDN driver, you will be presented with a prompt asking if you would like to install RAS. Respond "Yes" and install RAS before rebooting your computer. If RAS still does not recognize your adapter, remove the ISDN driver and try reinstalling it. If RAS is still unable to detect the ISDN driver, contact Technical Support for assistance (see Chapter 5).

- Q:** *Is it possible to build a point to point (end to end) videophone system based on the ISDN card?*
- A:** Yes, for versions after V2.24, a point to point videophone system is possible to set up. You'll need the following devices: ISDN Adapter, Sound Card with speaker and microphone, Video Capture Card, Camera, CPU:P-133, RAM 32M, VDOPhone.
- You'll need to add a virtual modem (ISDN Videophone adapter) which runs HDLC at 512 bytes per-packet (equal to ATB0S39+512). This string can also be added in the *Extra Setting* field of the ISDN Universal-1 or Universal-2 adapter if you do not have the new MDMASU.INF file.
- You may configure the VDOPhone application by selecting Setup>Modem, select the virtual modem defined above. Use Setup>Advanced and place a mark in the check box for *Use non H.324 compliant Modem*. Complete the other fields according to the requirements of the specific hardware you are using.
- Q:** *I would like to use G3Fax, a voice answering machine and telephony with my ISDN card in a Windows environment. How can I do this?*
- A:** Before using these functions you'll need to install a CAPI compliant application such as RVS-COM.
- Q:** *Can I use the MultiModemISDN adapter in a dual processor machine?*
- A:** Yes, In version 2.52, dual processors are supported in Windows NT and Windows 2000.

LINETest

Initiate the line test utility in Windows 2000 by clicking on the icon on the taskbar. Select **Line Test**. Enter your *ISDN telephone number* and click **Start**. The adapter will establish a test call. The status of the ISDN B and D channels between the terminal adapter and the ISDN switch network will display.

Note: Before using Line Test, make sure your ISDN line is not in use.

LineTest Error Messages (CAPI 2.0)

0x3301	protocol error layer 1
0x3302	protocol error layer 2
0x3303	protocol error layer 3
0x3304	another application got that call
0x3401	unsigned number
0x3402	no route to specified transmit network
0x3403	not route to destination
0x3406	channel unacceptable
0x3411	user busy
0x3412	no user responding
0x3413	no answer from user
0x3415	call reject
0x3416	number changed
0x341a	non-selected user clearing
0x341b	destination out of order
0x341c	invalid number format
0x341d	facility rejected
0x341e	response to status inquiry
0x341f	normal, unspecified

ISDN LOG

The ISDN *Log* utility provides six functions including: *Start/Stop*, *Save*, *Clear*, *Print*, *Option* and *Close*. The following figure (figure 4-1) shows a typical log screen. The upper text box of the Log dialog box displays ISDN communication information and the bottom section of the screen displays statistical details of the D and B-Channel events.

- In Windows 98, run LOG32.EXE in the Windows directory.
- In Windows NT, run LOG32.EXE located in \WINNT\SYSTEM32.
- In Windows 2000, right click on the STATS.EXE icon on the task bar and select **Log**.

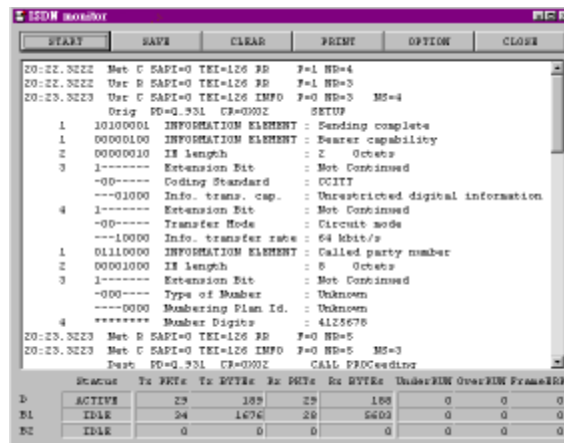

Figure 4-1. The ISDN Log

START/STOP: Begins or ends data logging.

SAVE: Saves the entire log history contents to a file. This file can be e-mailed or printed and faxed to our technical support center.

CLEAR: Clears the Log contents. You may want to save the data before erasing it.

PRINT: Sends the Log contents to the printer.

OPTION: The Options dialog box allows you to select specific line information for the ISDN D channel, B channels and CAPI messages to include in the Log.

CLOSE: Terminates the *ISDN Log* function.

Enable *Show statistic* to display the bottom section of the log as shown in figure 4-2. Information pertaining to the ISDN D channel is presented in a manner similar to that of a protocol analyzer. The information for the ISDN B channels and CAPI is presented in Hex format.

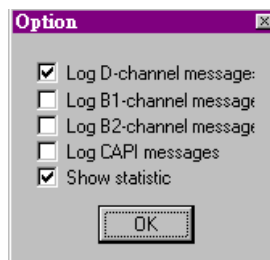

Figure 4-2. Options Dialog Box

ISDN Log Error Messages

You may encounter the following runtime problems:

1. **“Cannot find CTL3D.DLL”**. This message indicates that your Windows system does not support 3D graphics. The ISDN 128K driver will continue to execute normally without the 3D control graphic feature. You may contact your PC or system dealer to upgrade your Windows system if you would like this feature.
2. **“Irq Selftest Fail”**. This message indicates the ISDN 128K VxD driver failed its IRQ self-test. Check the IRQ values in System Resources by selecting **Start>Setting>Control Panel>System>Device Manager>ISDN card, ISDN PC Adapter>Resource**.
The PC system may have a non-PnP device using the same IRQ number as ISDN 128K adapter. This error is common in systems that have ISA bus sound cards installed using IRQ5. If your system identifies an IRQ conflict, select another IRQ (probably both hardware and software configurations) for this non-PnP device and reboot the system.
Windows 95 user can change the IRQ used by the ISDN card in the device manager by using **Start>Settings>Control Panel>System>Device Management>Multi-function adapters>ISDN PC Adapter (Master Device)>Properties>Resources**. Disable the *Use automatic settings* option. Select **Interrupt Request>Change Setting** and select an available IRQ value. If IRQ 5 is not available, IRQ 10 or 12 are often good choices. Ensure the IRQ you select is not in use by another device.
3. **“Cannot find ISDN card”**. This message indicates the ISDN 128K VxD driver does not find the ISDN 128K adapter when Windows starts. The problem may be associated with an I/O address or IRQ clash during PnP initialization. Check your system resources as describe in number 2 above. You may need to reinstall the ISDN 128K driver.

Chapter 5 - Warranty and Service

Multi-Tech Systems, Inc. Warranty & Repairs Policies

Multi-Tech Systems, Inc., (hereafter "MTS") warrants that its products will be free from defects in material or workmanship for a period of two, five, or ten years (depending on model) from date of purchase, or if proof of purchase is not provided, two, five, or ten years (depending on model) from date of shipment.

MTS MAKES NO OTHER WARRANTY, EXPRESS OR IMPLIED, AND ALL IMPLIED WARRANTIES OF MERCHANTABILITY AND FITNESS FOR A PARTICULAR PURPOSE ARE HEREBY DISCLAIMED.

This warranty does not apply to any products which have been damaged by lightning storms, water, or power surges or which have been neglected, altered, abused, used for a purpose other than the one for which they were manufactured, repaired by Customer or any party without MTS's written authorization, or used in any manner inconsistent with MTS's instructions.

MTS's entire obligation under this warranty shall be limited (at MTS's option) to repair or replacement of any products which prove to be defective within the warranty period or, at MTS's option, issuance of a refund of the purchase price. Defective products must be returned by Customer to MTS's factory – transportation prepaid.

MTS WILL NOT BE LIABLE FOR CONSEQUENTIAL DAMAGES, AND UNDER NO CIRCUMSTANCES WILL ITS LIABILITY EXCEED THE PRICE FOR DEFECTIVE PRODUCTS.

Repair Procedures for U.S. and Canadian Customers

In the event that service is required, products may be shipped, freight prepaid, to our Mounds View, Minnesota factory:

Multi-Tech Systems, Inc.
2205 Woodale Drive
Mounds View, MN 55112

Attn: Repairs, Serial # _____

A Returned Materials Authorization (RMA) is not required. Return shipping charges (surface) will be paid by MTS.

Please include, inside the shipping box, a description of the problem, a return shipping address (must have street address, not P.O. Box), your telephone number, and if the product is out of warranty, a check or purchase order for repair charges.

For out of warranty repair charges, go to: www.multitech.com

Extended two-year overnight replacement service agreements are available for selected products. Please call MTS at (888) 288-5470, extension 5308 or visit our web site at: www.multitech.com for details on rates and coverage.

Please direct your questions regarding technical matters, product configuration, verification that the product is defective, etc., to our Technical Support department at (800) 972-2439 or email: tsupport@multitech.com. Please direct your questions regarding repair expediting, receiving, shipping, billing, etc., to our Repair Accounting department at (800) 328-9717 or (763) 717-5631, or email: mtsrepair@multitech.com.

Repairs for damages caused by lightning storms, water, power surges, incorrect installation, physical abuse, or user-caused damages are billed on a time-plus-materials basis.

Repair Procedures for International Customers (Outside U.S.A. and Canada)

Your original point of purchase Reseller may offer the quickest and most economical repair option for your Multi-Tech product. You may also contact any Multi-Tech sales office for information about the nearest distributor or other repair service for your Multi-Tech product: [/www.multitech.com](http://www.multitech.com)

In the event that factory service is required, products may be shipped, freight prepaid to our Mounds View, Minnesota factory. Recommended international shipment methods are via Federal Express, UPS or DHL

courier services, or by airmail parcel post; shipments made by any other method will be refused. A Returned Materials Authorization (RMA) is required for products shipped from outside the U.S.A. and Canada. Please contact us for return authorization and shipping instructions on any International shipments to the U.S.A. Please include, inside the shipping box, a description of the problem, a return shipping address (must have street address, not P.O. Box), your telephone number, and if the product is out of warranty, a check drawn on a U.S. bank or your company's purchase order for repair charges. Repaired units shall be shipped freight collect, unless other arrangements are made in advance.

Please direct your questions regarding technical matters, product configuration, verification that the product is defective, etc., to our Technical Support department nearest you or email: tsupport@multitech.com. When calling the U.S., please direct your questions regarding repair expediting, receiving, shipping, billing, etc., to our Repair Accounting department at : +(763) 717-5631 or email: mtsrepair@multitech.com.

Repairs for damages caused by lightning storms, water, power surges, incorrect installation, physical abuse, or user-caused damages are billed on a time-plus-materials basis.

Repair Procedures for International Distributors

Procedures for International Distributors of Multi-Tech products are on the distributor web site: www.multitech.com

Online Warranty Registration

If you have access to the World Wide Web, you can register your Multi-Tech product online at: www.multitech.com

Service

U.S. and Canadian Customers

In the event that service is required, products may be shipped, freight prepaid, to our Mounds View, Minnesota, factory:

Multi-Tech Systems, Inc.
2205 Woodale Drive
Mounds View, MN 55112

Attn: Repairs, Serial # _____

A Returned Materials Authorization (RMA) is not required. Return shipping charges (surface) will be paid by MTS. Please include inside the shipping box a description of the problem, a return shipping address (must have street address, not P.O. Box), a telephone number, and if the product is out of warranty, a check or purchase order for repair charges.

For out of warranty repair charges, go to www.multitech.com

Extended two-year overnight replacement agreements are available for selected products. Please call MTS at 888 288-5470, extension 5308, or visit our web site at: www.multitech.com for details on rates and coverages.

Please direct your questions regarding technical matters, product configuration, verification that the product is defective, etc., to our Technical Support department at 800 972-2439 or e-mail tsupport@multitech.com.

Please direct your questions regarding repair expediting, receiving, shipping, billing, etc., to our Repair Accounting department at 800 328-9717 or +763 785-3500, or e-mail mtsrepair@multitech.com.

Repairs for damages caused by lightning storms, water, power surges, incorrect installation, physical abuse, or user-caused damages are billed on a time-plus-materials basis.

International Customers (outside U.S.A. and Canada)

Your original point of purchase reseller may offer the quickest and most economical repair option for your Multi-Tech product. You may also contact any Multi-Tech sales office for information about the nearest distributor or other repair service for your Multi-Tech product: www.multitech.com

In the event that factory service is required, products may be shipped, freight prepaid, to our Mounds View, Minnesota, factory. Recommended international shipment methods are via Federal Express, UPS or DHL courier services, or by airmail parcel post; shipments made by any other method will be refused. A Returned Materials Authorization (RMA) is required for products shipped from outside the U.S.A. and Canada. Please contact us for return authorization and shipping instructions on any international shipments to the U.S.A. Please include, inside the shipping box, a description of the problem, a return shipping address (must have street address, not P.O. Box), your telephone number, and if the product is out of warranty, a check drawn on a U.S. bank or your company's purchase order for repair charges. Repaired units will be shipped freight collect, unless other arrangements are made in advance.

Please direct questions regarding technical matters, product configuration, verification that the product is defective, etc., to our Technical Support department nearest you, as listed at: www.multitech.com or e-mail: tsupport@multitech.com. When calling the U.S., please direct questions regarding repair expediting, receiving, shipping, billing, etc., to our Repair Accounting department at +763 717-5631 in the U.S.A., or e-mail: mtsrepair@multitech.com.

Repairs for damages caused by lightning storms, water, power surges, incorrect installation, physical abuse, or user-caused damages are billed on a time-plus-materials basis.

International Distributors

Procedures for international distributors of Multi-Tech products are on the Distributor Web site at: www.multitech.com.

Replacement Parts

SupplyNet, Inc., can supply you with replacement power supplies, cables and connectors for selected Multi-Tech products. You can place an order with SupplyNet via mail, phone, fax or the Internet at the following addresses:

Mail: SupplyNet, Inc.
614 Corporate Way
Valley Cottage, NY 10989
Phone: 800 826-0279
Fax: 914 267-2420
Email: info@thesupplynet.com
Internet: www.thesupplynet.com

Technical Support

Multi-Tech Systems has an excellent staff of technical support personnel available to help you get the most out of your Multi-Tech product. If you have any questions about the operation of this unit, please call 800 972-2439 (USA and Canada) or 763 785-3500 (international and local). Please have modem information available. You can also contact Technical Support by e-mail at the following addresses:

France:	support@multitech.fr	+(33) 1-64 61 09 81
India:	support@multitechindia.com	+91 (124) 6340778
U.K.:	support@multitech.co.uk	+(44) 118 959 7774
U.S., Canada	tsupport@multitech.com	800 972-2439
Worldwide:	tsupport@multitech.com	+763 717-5863

Please note the status of the modem before contacting Technical Support. Status information can include the state of the LED indicators, screen messages, diagnostic test results, problems with a specific application, etc.

Internet Sites

Multi-Tech is a commercial provider on the Internet. Multi-Tech has a Web site at: www.multitech.com

Appendix A - Regulatory Agency Information

FCC Part 68 Telecom Digital

1. This equipment complies with part 68 of the Federal Communications Commission Rules. On the outside surface of this equipment is a label that contains, among other information, the FCC registration number. This information must be provided to the telephone company.
2. As indicated below, the suitable jack (Universal Service Order Code connecting arrangement) for this equipment is shown. If applicable, the facility interface codes (FIC) and service order codes (SOC) are shown.
3. A FCC-compliant telephone cord and modular plug is provided with this equipment. This equipment is designed to be connected to the telephone network or premises wiring using a compatible modular jack which is Part 68 compliant. See installation instructions for details.
4. If this equipment causes harm to the telephone network, the telephone company will notify you in advance that temporary discontinuance of service may be required. But if advance notice is not practical, the telephone company will notify the customer as soon as possible. Also, you will be advised of your right to file a complaint with the FCC if you believe it is necessary.
5. The telephone company may make changes in its facilities, equipment, operations, or procedures that could affect the operation of the equipment. If this happens, the telephone company will provide advance notice in order for you to make necessary modifications in order to maintain uninterrupted service.
6. If trouble is experienced with this equipment (the model of which is indicated below) please contact MultiTech Systems, Inc. at the address shown below for details of how to have repairs made. If the equipment is causing harm to the network, the telephone company may request you to remove the equipment from the network until the problem is resolved.
7. No repairs are to be made by you. Repairs are to be made only by MultiTech Systems or its licensees. Unauthorized repairs void registration and warranty.
8.

Manufacturer:	MultiTech Systems, Inc.
Trade Name:	MultiModemISDN
Model Number:	MT128PCI-SD
FCC Registration Number:	AU7XDNANMT128
Modular Jack (USOC):	RJ49C
Service Order Code (SOC):	6.0F
Service Center in USA:	MultiTech Systems, Inc. 2205 Woodale Drive Mounds View, MN 55112 (612) 785-3500 Fax (612) 785-9874

Class B Statement

FCC Part 15

This equipment has been tested and found to comply with the limits for a Class B digital device, pursuant to Part 15 of the FCC Rules. These limits are designed to provide reasonable protection against harmful interference in a residential installation. This equipment generates, uses and can radiate radio frequency energy and, if not installed and used in accordance with the instructions, may

cause harmful interference to radio communications. However, there is no guarantee that interference will not occur in a particular installation. If this equipment does cause harmful interference to radio or television reception, which can be determined by turning the equipment off and on, the user is encouraged to try to correct the interference by one or more of the following measures:

- Reorient or relocate the receiving antenna.
- Increase the separation between the equipment and receiver.
- Connect the equipment into an outlet on a circuit different from that to which the receiver is connected.
- Consult the dealer or an experienced radio/TV technician for help.

This device complies with Part 15 of the FCC rules. Operation is subject to the following two conditions:

- (1) This device may not cause harmful interference.
- (2) This device must accept any interference that may cause undesired operation.

Warning: Changes or modifications to this unit not expressly approved by the party responsible for compliance could void the user's authority to operate the equipment.

Industry Canada

This Class B digital apparatus meets all requirements of the Canadian Interference-Causing Equipment Regulations.

Cet appareil numérique de la classe B respecte toutes les exigences du Règlement sur le matériel brouilleur du Canada.

Canadian Limitations Notice

Notice: The Industry Canada label identifies certified equipment. This certification means that the equipment meets certain telecommunications network protective, operational and safety requirements. The Industry Canada does not guarantee the equipment will operate to the user's satisfaction.

Before installing this equipment, users should ensure that it is permissible to be connected to the facilities of the local telecommunications company. The equipment must also be installed using an acceptable method of connection. In some cases, the inside wiring associated with a single-line individual service may be extended by means of a certified connector assembly. The customer should be aware that compliance with the above conditions may not prevent degradation of service in some situations.

Repairs to certified equipment should be made by an authorized Canadian maintenance facility designated by the supplier. Any repairs or alterations made by the user to this equipment, or equipment malfunctions, may give the telecommunications company cause to request the user to disconnect the equipment.

Users should ensure for their own protection that the electrical ground connections of the power utility, telephone lines and internal metallic water pipe system, if present, are connected together. This precaution may be particularly important in rural areas.

Caution: Users should not attempt to make electrical ground connections themselves, but should contact the appropriate electric inspection authority or an electrician, as appropriate.

EMC, Safety and Terminal Directive Compliance

The CE mark is affixed to this product to confirm compliance with the following European Community Directives:

Council Directive 89/336/EEC of 3 May 1989 on the approximation of the laws of Member States relating to electromagnetic compatibility.

and

Council Directive 73/23/EEC of 19 February 1973 on the harmonization of the laws of Member States relating to electrical equipment designed for use within certain voltage limits:

and

Council Directive 98/13/EC of 12 March 1998 on the approximation of the laws of Member States concerning telecommunications terminal and Satellite earth station equipment.

Appendix B - APIs

This Appendix describes the APIs (Application Program Interfaces) used with the MT128ISA and MT128PCI ISDN terminal adapters.

An API is a set of routines, protocols, and tools for building software applications. A good API makes it easier to develop an application by providing all the building blocks for a programmer to use in the development process. Most operating environments, such as MS-Windows, provide an API so that programmers can write applications consistent with the operating environment. Programs developed using a common API will have a similar user interface, making it easier to learn the new program.

The three basic APIs used with the MT128ISA and MT128PCI ISDN terminal adapters are VCOMM, CAPI and NDIS. The support provided for each API by the ISDN drivers is dependent upon the operating system used.

VCOMM

Multi-Tech's ISDN adapters support the *VCOMM (Microsoft Windows Comm)* API interface. VCOMM is essentially a virtual communications port emulator (a virtual modem) which provides protected-mode services allowing Windows-based applications and drivers to use ports and modems. To conserve system resources, communications drivers are loaded into memory only when in use by applications.

This interface is similar to a modem interface and enables existing applications based on AT commands to access ISDN. This feature is called the *Comport Emulator* and allows AT commands to enable ISDN features such as HDLC, X.75, V.120, or Async to Sync PPP (note this emulation does NOT support fax features).

Windows 98 have the VCOMM API enabled automatically. VCOMM can only provide AT-emulation if the application requests its COM port services from Windows. It cannot support the application if it tries to access the COM port hardware directly or if your software does not use the standard VCOMM driver interface.

Windows NT and **Windows 2000** do not support VCOMM.

CAPI

CAPI (Common ISDN Application Programming Interface) is an application programming interface standard used to access ISDN equipment. When an application wants to communicate with an ISDN card it sends a standard series of commands to the card. These commands form the CAPI standard and give developers and users a chance to use a well-defined mechanism for communications over ISDN lines without being forced to adjust to hardware idiosyncrasies.

CAPI drivers take over total control of your COM port and act as a switch for any other CAPI compatible applications. While in CAPI mode, instead of DUN (Dial-up Networking) opening and using the "real" COM port, your system uses a "virtual" COM port. A common CAPI application which creates this "virtual" COM port is RVS-COM. To DUN, this virtual COM port looks like a physical COM port. If your machine has two physical COM ports (COM1 and COM2), RVS-COM creates the first virtual port as the next available port (COM3).

RVS-COM allows you to take full advantage of the CAPI API by providing for processes such as sending and receiving faxes, receiving voice mail, using a full duplex sound card as a telephone, transferring files from PC to PC, using terminal emulation for BBS and online systems as well as accessing the Internet via ISDN.

NDIS

NDIS (Network Device Interface Specification) was developed by Microsoft and 3COM. It is a Windows device driver interface that enables a single network interface card (NIC) to support multiple network protocols. For example, with NDIS a single NIC can support both TCP/IP and IPX connections. Certain ISDN adapters, such as the MT128ISA and MT128PCI can also use NDIS.

NDIS includes a protocol manager that accepts requests from the network driver (at the transport layer) and passes these requests to the NIC (at the data link layer), allowing multiple NDIS-conforming network drivers to co-exist. In a situation where a computer contains multiple NIC's because it is connected to more than one network, NDIS can route traffic to the correct card.

Appendix C - Applications

This appendix provides an introduction to popular applications that can be utilized with your ISDN TA adapter.

TRUMPET Setup through COM Port Emulation

In Windows 95 and Windows 98, the virtual COM port driver will automatically be enabled on system startup through Microsoft's Windows Comm. API (VCOMM).

Microsoft HyperTerminal

HyperTerminal was designed for Microsoft by Hilgraeve Inc. and is provided with Windows 98, Windows NT and Windows 2000. The program provides a simple set of communication tools to make getting on-line easy. HyperTerminal can also be used to obtain diagnostic information from your modem after a session with your ISP or to make test calls to an ISP.

If you are trying to use the HyperTerminal for a point to point connection, you'll need to set up a virtual modem attached to your ISDN ComPort. Please refer to Chapter 2 for more information on setting up an ISDN connection for a virtual modem for your operating system. Whether you use the ISDN (X.75 Transparent, 64K) adapter modems or universal modems, to use the X.75 protocol, you must include the ATB3n command in the Advanced Connection Settings screen as shown below.

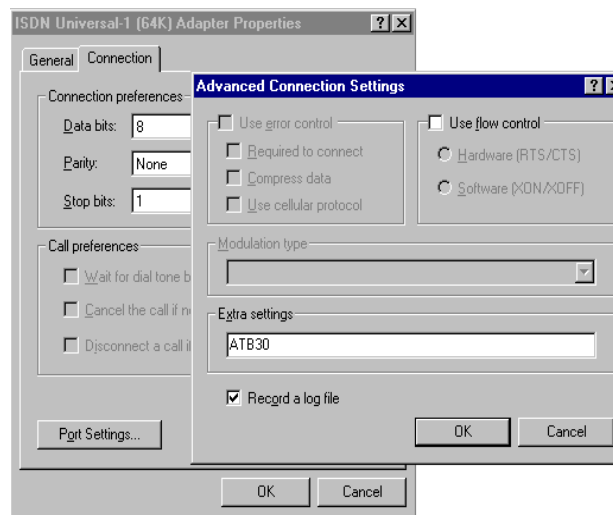

Figure C-1. HyperTerminal for Point to Point or BBS Connection

At the receiving site, enter `ATS0=1` to automatically answer incoming calls. Note that the default protocol in the B channel is HDLC 64K with packet size 2048. If you would like to change the B channel protocol use the following steps.

Go to extra setting field : **Start>Settings>Control panel>Modems>Properties>Connection>Advanced>Extra settings.**

You can improve reliability and performance by changing the packet size for the B channel to 512 bytes. Change this setting permanently by entering "`ATS39 = 512`" in the Extra Setting field. If you would like the B channel protocol, packet or Window size to be reset to default values when the application is finished, you may input these values manually. For example, to select a X.75 Transparent with 1024 packet size for B channel connection use, `ATB30S45=1024`.

Index

A

APIs 40
Appendices 7
Application Interfaces 8
AT COMMANDS 25

B

B-Channel Protocols 8
Before You Begin 14
BOD 15
BRI Connections 13

C

Canadian Limitations Notice 38
CAPI 14
Class B Statement 38
Codec 16
Configure Port Usage 19
Configuring for Your ISDN Switch 16
Connections 13

D

Determining your modem type 14

E

EMC, Safety and Terminal Directive Compliance 39
Environment Setup 11
Error Messages 32

F

FCC 37
Features 5, 6
Frequently Asked Questions 28

H

Hardware 8
HDLC 15

I

Internet Access 11
Internet addresses 36
ISA 12
ISDN BRI Line 9
ISDN LOG 31
ISDN Switch Type 16

L

LINETEST 30

M

Manual Organization 7
MLPPP 15
Model Number(s) 8
MSN (POTS) 16
Multi-Tech Internet sites 36

N

NDISWAN 14
Network Interface 8
NT1 Connection 9

O

ordering replacement parts 36

P

PCI 12
PPP 15
Product Description 5
Protocol 16

R

registering your product 34
Regulatory Agency Information 37
Remote Access Service 18
Remote Access Services (RAS) Setup 19
replacement parts 36
RVS-COM Lite 14

S

S/T Interface Connector Specification 10
SAD 16
Safety Warnings 11
Specifications, technical 8
SPID 16
Standby Time 16
Supported Applications 8
Switch Compatibility 8

T

Terminator Setup 12
Troubleshooting 28

U

U interface connector specification 10

V

VCOMM 14

Voice

coding 8

W

What Is in Your MultiModemISDN Package? 6

Windows 2000 Installation and Configuration 25

Windows NT and the CAPI Interface 22

Windows NT Installation and Configuration 17

Windows NT Multilinked Channel Access (CAPI) 24

Windows NT Multilinked Channel Access

(NDISWAN) 21

Windows NT Removal of the ISDN Drivers 24

Windows NT Single Channel Access (CAPI) 24

Windows NT Single Channel Access (NDISWAN)

20

X

X.75 protocol 15